

4 mm BOYUNCA
 TEK OLCUM $\phi +0.2$
 ORTALAMA $\phi +0.3\text{mm}$

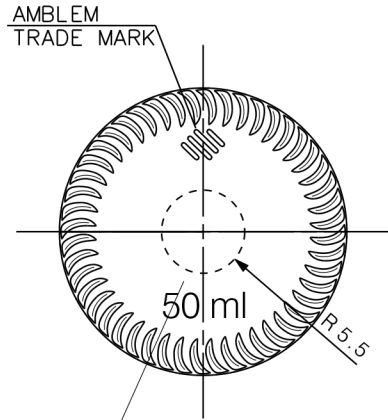

KALIP NO (S-7 S)
 MOLD NO (S-7 S)

Şişecam Cam Ambalaj
 Tasarım Müdürlüğü
 Tarafından Çizilmiştir.
 06.04.17

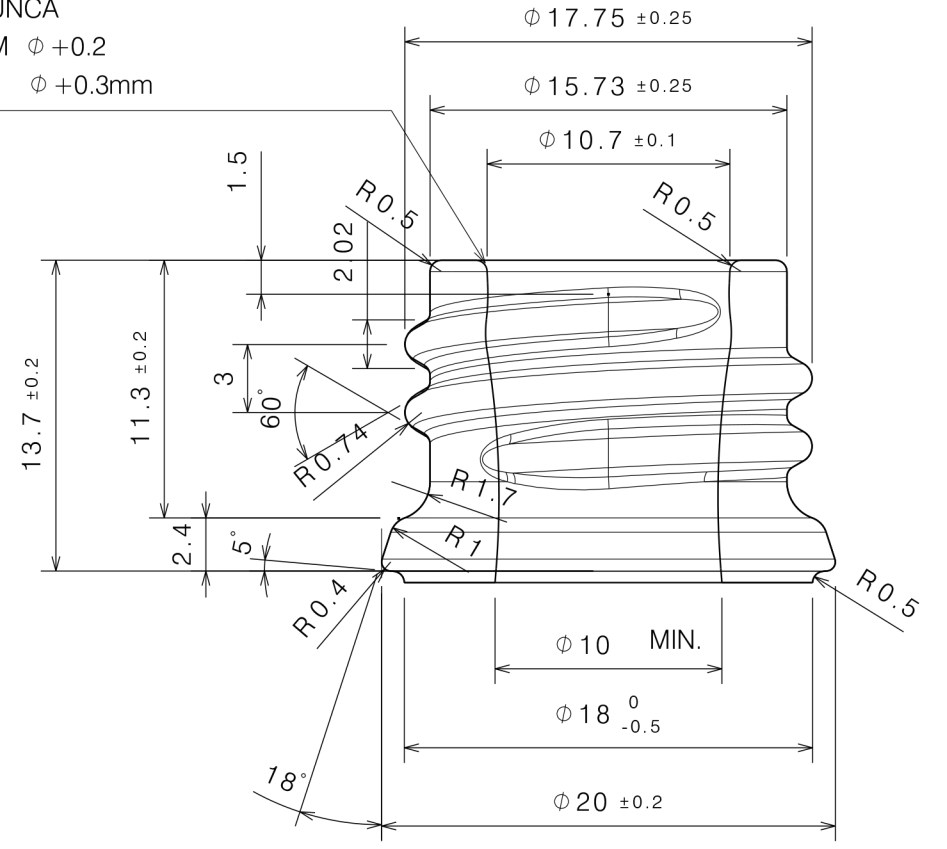

HATVE PITCH : 3

HELIS ACISI HELIX ANGLE : $3^\circ 16'$

FREZE CAKI CAPI : 9.5

DIA. OF MILLING CUTTER